

## INSULATED HALF-SIZE HOT CABINET H-339 SERIES (FOR 18" X 26" PANS)

### FEATURES AND BENEFITS:

- Fully insulated half-size holding cabinet keeps prepared foods at serving temperatures. Ideal for transport
- Powerful, yet efficient, 900 Watt heating system maintains the right temperature to properly hold products. Heats up to 200°F (93°C).
- Internal frame in body and door maintains structural rigidity.
- Body constructed of non-corrosive, Hi-Tensile aluminum for strength and ease of mobility. One piece extended base protects cabinet body.
- Safety-conscious anti-microbial latch protect against spreading germs.
- Insulated field reversible door for flexibility. Standard with right hand hinging; left hand hinging available upon request.
- Magnetic latch for "easy open"; twist-lock catch secures door during transport. Latch and hinges mounted inboard.
- Removable pan supports for easy cleaning. Models available:
  - Wire supports for 18" x 26" pans on 2-3/4" centers. Model H-339-188C
  - Wire supports for 18" x 26" pans and 12" x 20" pans on 2-3/4" centers. Model H-339-12-188C
  - Corrugated supports for 18" x 26" pans on 1-1/2" centers. Model H-339-1813C
- Pan stops on inside of door and back allow for proper air flow.
- Convenient lift handles fold flat against sides of cabinet.
- Heavy duty 5" swivel casters, two with brakes. Provides mobility when fully loaded.
- Cabinets can be stacked for flexibility; specify optional stacking kit.



H-339-12-188C



NSF/ANSI 4



C US



ENERGY STAR

### ACCESSORIES and OPTIONS (Available at extra cost):

- Key Lock Handle
- Stacking Kit
- Pass-Thru Version
- Corner Bumpers
- Perimeter Bumper
- Various Caster Options
- Digital Thermometer
- 240 Volt Service

See page B-20 for accessory details.

# H-339 Series (18" x 26" Pans)

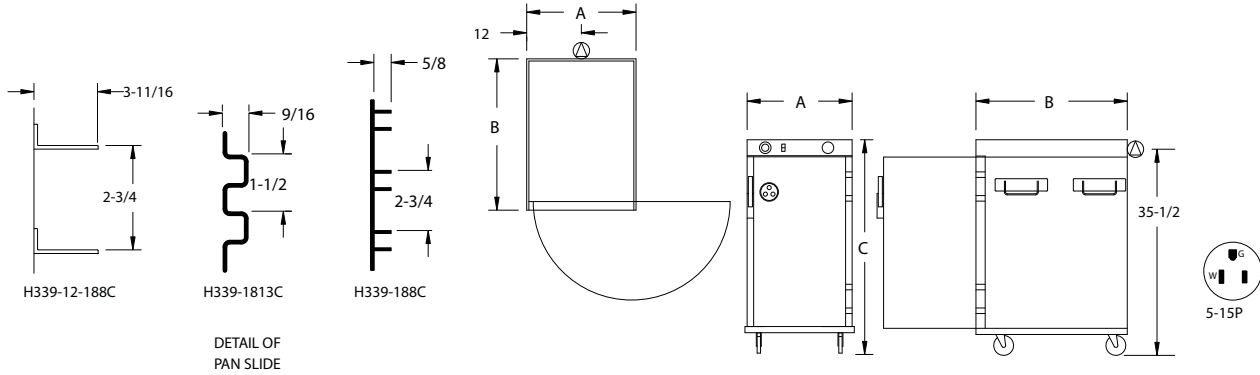

CRES COR MODEL NO.	PAN			DIM "A"	DIM "B"	DIM "C"	INSIDE DIMENSIONS			WEIGHT ACT.	
	CAP	SIZE		WIDTH	DEPTH	HEIGHT	WIDTH	DEPTH	HEIGHT		
H-339-188C	8	18 x 26	IN	23-7/8	32-1/4	36-11/16	18-3/16	26-1/4	24-7/8	LBS	139
		460 x 660	MM	610	820	935	465	670	635	KG	63
H-339-12-188C	8*	18 x 26	IN	23-7/8	32-1/4	36-11/16	18-3/16	26-1/4	24-7/8	LBS	139
		460 x 660	MM	610	820	935	465	670	635	KG	63
H-339-1813C	13	18 x 26	IN	23-7/8	32-1/4	36-11/16	18-3/16	26-1/4	24-7/8	LBS	139
		460 x 660	MM	610	820	935	465	670	635	KG	63

NOTES: 1. Will also carry 12" x 20" pans, capacity 8.  
 2. When ordering bumpers, add 2" to overall dimensions.  
 ALL CONSTRUCTION IS RIVETED, WELDED AND FINISHED.

### CABINET:

- Body: .063 aluminum.
- Reinforcement: Internal framework of channels, 1 x 3/4 x .125.
- Insulation: Fiberglass, thermal conductivity (K factor) is .23 at 75°F. 1-1/2" in walls; 1" in door, top and bottom.
- Pan stop channels: Mounted to inside rear of cabinet and door.
- Bail handles (4): Two mounted to each side.

### BASE:

- One piece construction, .190 aluminum.
- Casters: 5" dia., swivel, modulus tires, 1-1/4 wide, load cap. 250 lbs. each, temp. range -45°/+180°F. Delrin bearings. Front casters equipped with brakes.

### DOOR:

- Field reversible.
- Formed .063 aluminum.
- Latch: Chrome plated zinc with composite handle, magnetic type; mounted inboard.
- Hinges: Heavy duty chrome plated zinc; mounted inboard.
- Gasket: Perimeter type, silicone.
- Transport latch.
- Vent: Adjustable.

### PAN SLIDES:

- H-339-188C, H-339-12-188C: Flat wire racks, .104 x 5/8 nickel chrome plated steel, spaced on 2-3/4" centers.
- H-339-1813C: Corrugations act as pan slides on 1-1/2" centers.

### ELECTRICAL COMPARTMENT:

- Cover: Formed .100 aluminum fastened to cabinet top.
- Control panel: Formed .063 aluminum; black front.
- Thermostat: Electro-mechanical, room ambient to 200°F (93°C).
- Switch: Lighted ON-OFF rocker type.
- Power cord: Removable, 6 ft., 14/3 ga. with molded straight plug.
- Heaters (3): 300 Watts each.
- Thermometer.

### POWER REQUIREMENTS:

- 900 Watts, 120 Volts, 60 Hz., single phase, 7.5 Amps., 15 Amp. service.

### SHORT FORM SPECIFICATIONS

Cres Cor Half-Size Insulated Hot Cabinet Model H-339-\_\_\_\_\_C. Inner, outer and top liners of .063 aluminum, reinforced with channel frame. Field reversible, formed .063 aluminum door. Fiberglass insulation in walls 1-1/2"; door, top and bottom 1". Welded and finished .190 aluminum base. (3) 300 Watt inner wall heaters, 120 Volts. Removable pan supports for (\_\_\_\_) 18" x 26" pans or (\_\_\_\_) 12" x 20" pans. Two bail handles on each side. 5" swivel modulus casters, Delrin bearings. Load capacity 250 lbs. each. 2 year parts warranty. Provide the following accessories: \_\_\_\_\_, CSA-US, CSA-C, CSA to NSF4 listed. ENERGY STAR Qualified.



5925 Heisley Road • Mentor, OH 44060-1833  
 Phone: 877/CRESCOR • Fax: 440/350-7267  
 www.crescor.com

© Crescent Metal Products, Inc. 2010 All rights reserved.

*In line with its policy to continually improve its products, CRES COR reserves the right to change materials and specifications without notice.*

Litho in U.S.A.